

REVISION RECORD			
REV.	CONTENT	MOD.	DATE
△	初版发行		

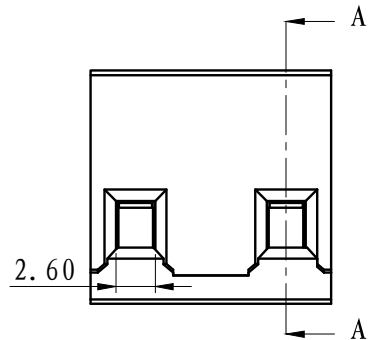
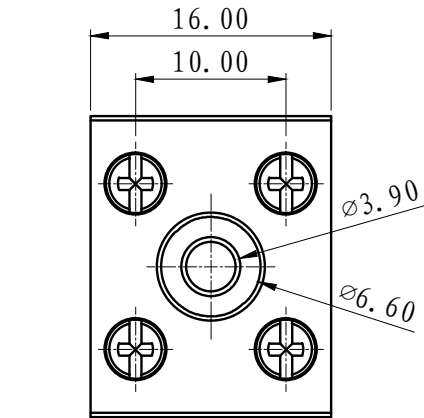

NOTES1:

UL Standard:

1. Voltage Rating: 300V, Current Rating: 15A

IEC Standard:

1. Voltage Rating: 320V, Current Rating: 17.5A

NOTES2:

1. PITCH: 10.0mm
2. Insulation Withstands Voltage: AC2500V/min
3. Insulation Resistance: 500MΩ or more at DC500V
4. Using Temperature Range: -40° C - +105° C
5. Suitable Electric Wire: 26-14AWG
6. Screw Torque Value: 0.4 N.m

技术要求1:

UL 标准:

1. 额定电压: 300V, 额定电流: 15A

IEC 标准:

1. 额定电压: 320V, 额定电流: 17.5A

技术要求2:

1. 间距: 10.0mm
2. 耐压值: AC 2500V/min
3. 绝缘阻抗: 500兆欧
4. 使用条件: -40° C - +105° C
5. 适用线规: 26-14AWG
6. 螺丝扭力: 0.4 N.m

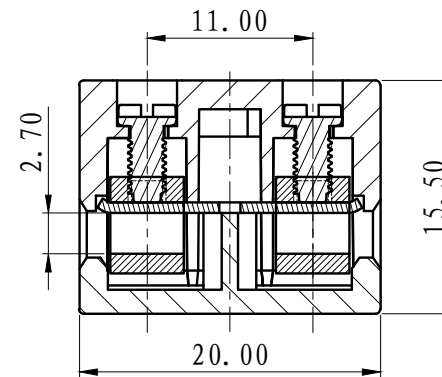

SECTION A-A

	pitch dimension			Nominal dimension					— ▱ ⌒
	over 0 to 6	over 6 to 10	over 10 to 24	over 0 to 30	over 30 to 60	over 60 to 100	over 100 to 150	over 150	
variable range	0 to 6	6 to 10	10 to 24	0 to 30	30 to 60	60 to 100	100 to 150	150	0.05/10
Tolerance	±0.1	±0.15	±0.25	±0.2	±0.3	±0.5	±0.7	±1.0	0.05/10

5	LG128-铜方块	F1A0BLG1283V	4	黄铜	镀镍
4	LG128-螺丝 (十一字半头底部无牙)	SP0FA255101V	4	碳钢	三价铬钝化彩锌
3	H3802-导电件	4013B0010AV	2	黄铜	镀雾锡
2	H3802-C-盖板	4021A0Y02AV	1	PC	
1	H3802-C-本体	4021A0Y02AV	1	PC	
NO.	NAME OF PART	NO. OF PART	Q' TY	MATERIAL	NOTES
DES.	WY	DATE	2021/6/11	UNITS	MM
CHK.		DATE		SIZE	A4
APP.		DATE		SCALE	1:1
				DWG NO.	SP-2-4021001
				REV:	V0
上海联捷电气有限公司 Shanghai Elinker Electric Co., LTD				TITLE	H3802-C-2P-1Y-00A H3802-C-成品