

REVISION RECORD			
REV.	CONTENT	MOD.	DATE
△	初版发行		

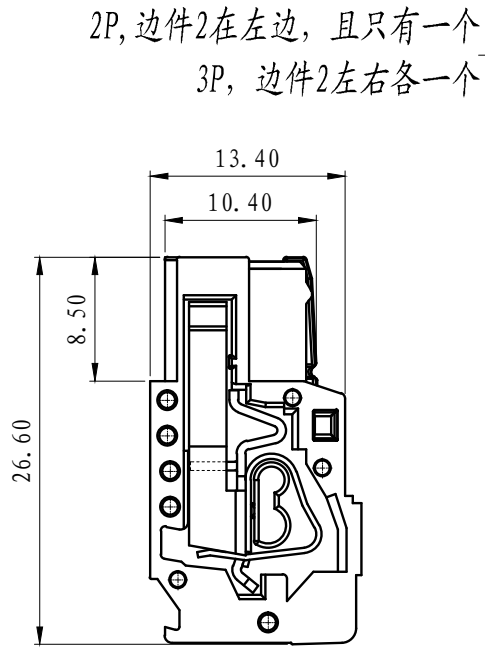

2P, 边件2在左边, 且只有一个
3P, 边件2左右各一个

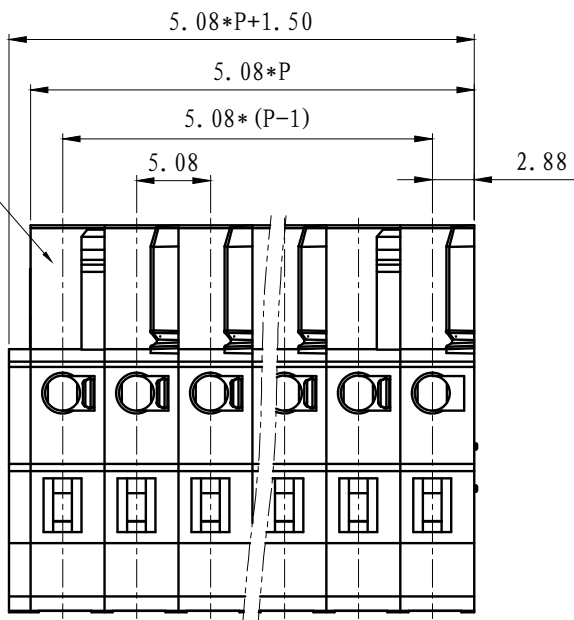
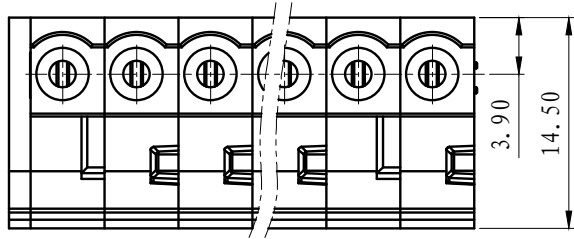

NOTES:
Pitch : 5.08mm
Rated Voltage : 300 V
Rated Current : 15 A
Withstand Voltage :
AC2500V for 1 minute
Insulation Resistance :
500MΩ / DC500V
Using Temperature Range :
-40℃ ~ +105℃
Wire range : 22~ 14AWG
Stripping length : 6mm

技术要求:
间距: 5.08mm
额定电压: 300V
额定电流: 15A
耐电压值: AC2500V/min
绝缘阻抗: 500MΩ/DC500V
使用条件: -40℃~+105℃
适用线规: 22~ 14AWG
剥线长度: 6mm

	pitch dimension			Nominal dimension					— /
	over 0	over 6	over 10	over 0	over 30	over 60	over 100	over 150	
variable range	to 6	to 10	to 24	to 30	to 60	to 100	to 150		□ ○
Tolerance	±0.1	±0.15	±0.25	±0.2	±0.3	±0.5	±0.7	±1.0	0.05/10

5	LSC1-弹片	F2A0DLSLC1BV	P	不锈钢	
4	LSC1-夹子	1056B0001AV	P	磷青铜	镀镍
3	LSC1-5.08-盖板	1056C0Y01AV	1	PA66-V0	
2	LSC1-5.08-中间件	1057A0Y01AV	P-2	PA66-V0	
1	LSC1-5.08-边件2	1058A0Y01AV	2	PA66-V0	
NO.	NAME OF PART	NO. OF PART	Q'TY	MATERIAL	NOTES
DES.	LDD	DATE	2012/08/15	UNITS	mm
CHK.		DATE		SIZE	A4
APP.		DATE		SCALE	
				DWG NO.	SP-2-1058001
				REV:	V0
 上海联捷电气有限公司 Shanghai Elinker Electric CO.,LTD				TITLE	LSC1B-5.08-XXP-1Y-00A
					LSC1B-5.08-成品