

REVISION RECORD			
REV.	CONTENT	MOD.	DATE
△	初版发行		

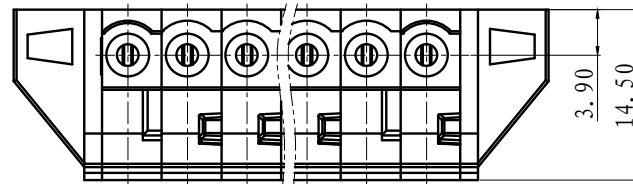

NOTES:

Pitch : 5.08mm
 Rated Voltage : 300 V
 Rated Current : 15 A
 Withstand Voltage :
 AC2500V for 1 minute
 Insulation Resistance :
 500MΩ / DC500V
 Using Temperature Range :
 -40℃ ~ +105℃
 Wire range : 22~ 14AWG
 Stripping length : 6mm

技术要求:

间距: 5.08mm
 额定电压: 300V
 额定电流: 15A
 耐压值: AC2500V/min
 绝缘阻抗: 500MΩ/DC500V
 使用条件: -40℃~+105℃
 适用线规: 22~ 14AWG
 剥线长度: 6mm

2P, 边件2在左边, 且只有一个
 3P, 边件2左右各一个

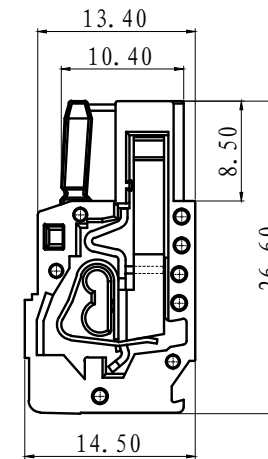
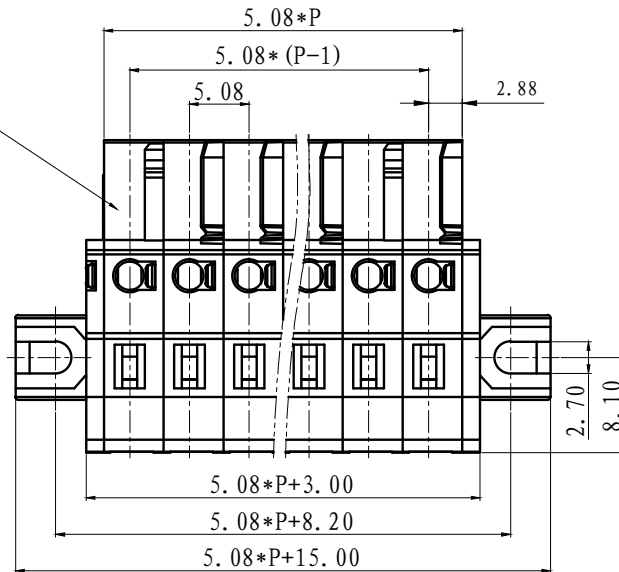

	pitch dimension			Nominal dimension					— /
	over 0	over 6	over 10	over 0	over 30	over 60	over 100	over 150	
variable range	to 6	to 10	to 24	to 30	to 60	to 100	to 150		▱ ○
Tolerance	±0.1	±0.15	±0.25	±0.2	±0.3	±0.5	±0.7	±1.0	0.05/10

6	LSC1-夹子	1056B0001AV	P	磷青铜	镀镍
5	LSC1-弹片	F2A0DLSLC1BV	P	不锈钢	
4	LSC1M-5.08-盖板2	1066C0Y01AV	1	PA66-V0	
3	LSC1M-5.08-盖板1	1065C0Y01AV	1	PA66-V0	
2	LSC1-5.08-中间件	1057A0Y01AV	P-2	PA66-V0	
1	LSC1-5.08-边件2	1058A0Y01AV	2	PA66-V0	

NO.	NAME OF PART	NO. OF PART	Q'TY	MATERIAL	NOTES
DES.	LDD	DATE	2012/08/15	UNITS	mm
CHK.		DATE		SIZE	A4
APP.		DATE		SCALE	
				DWG NO.	SP-2-1058003
				TITLE	LSC1MB-5.08-XXP-1Y-00A
					LSC1MB-5.08-成品



上海联捷电气有限公司
 Shanghai Elinker Electric CO.,LTD

TITLE

LSC1MB-5.08-XXP-1Y-00A
 LSC1MB-5.08-成品