

REVISION RECORD

REV.	CONTENT	MOD.	DATE
△	初版发行		

NOTES:

Pitch : 5.08mm
 Rated Voltage : 300V
 Rated Current : 15A
 Withstand Voltage :
 AC2500V for 1 minute
 Insulation Resistance :
 500MΩ / DC500V
 Using Temperature Range :
 - 40℃ ~ + 105℃
 Wire range : 24~12 AWG
 Screw Torque Value : 0.8Nm
 Ploe:2-24

技术要求:

间距: 5.08mm
 额定电压: 300V
 额定电流: 15A
 耐电压值: AC2500V/min
 绝缘阻抗: 500MΩ/DC500V
 使用条件: -40℃~+105℃
 适用线规: 24~12 AWG
 螺丝扭矩: 0.8 Nm
 极数: 2-24P

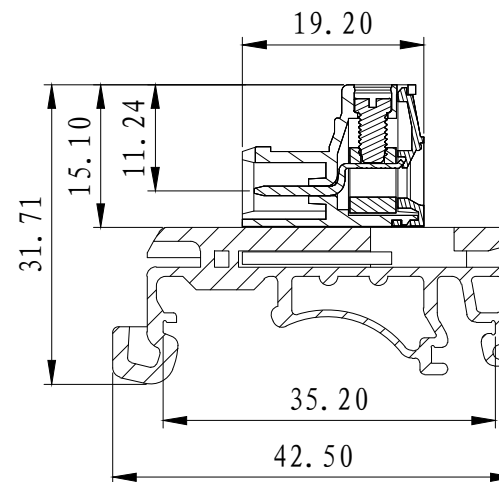
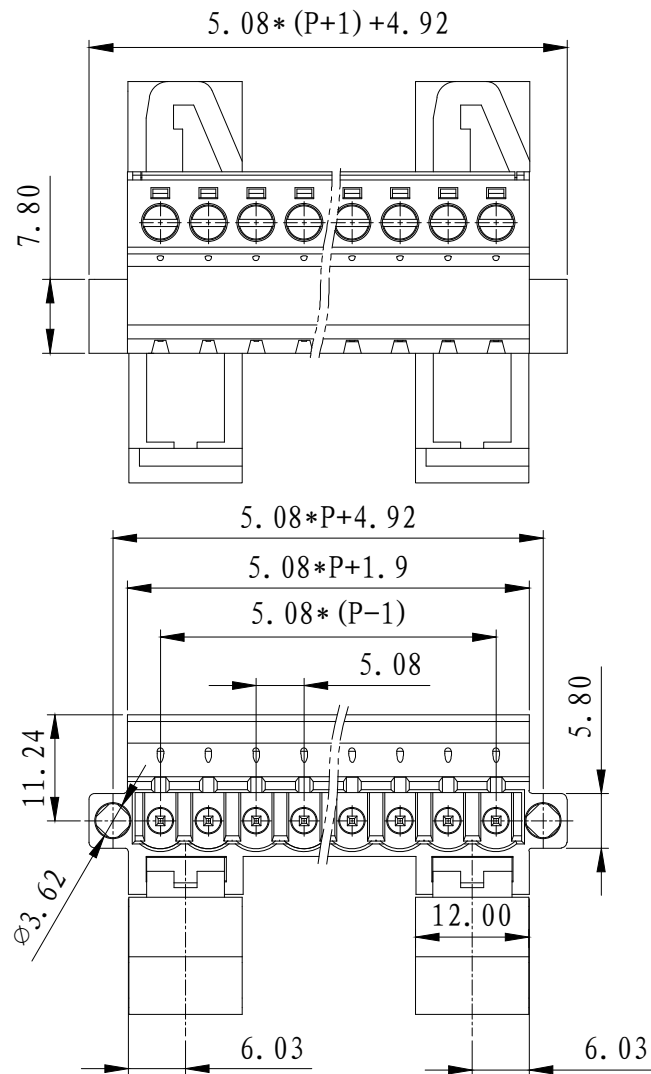

	pitch dimension			Nominal dimension					— ▱ ⌒
	over 0 to 6	over 6 to 10	over 10 to 24	over 0 to 30	over 30 to 60	over 60 to 100	over 100 to 150	over 150	
variable range	0	6	10	0	30	60	100	150	▱
Tolerance	±0.1	±0.15	±0.25	±0.2	±0.3	±0.5	±0.7	±1.0	⌒

6	LC10-5.08-焊脚	1011B0001AV	P	紫铜	镀雾锡
5	LC1-5.08-螺丝	SP0YA305301V	P	碳钢	三价铬钝化彩锌
4	LC1-5.08-铜方块	F1A0BLC5083V	P	黄铜	镀镍
3	LC1-5.08-盖板	1001C0YXXAV	1	PA66-V0	
2	LC16-5.08脚	1045T0Y01AV		PA66-V0	
1	LC16MG-5.08本体	1045N0YXXAV	1	PA66-V0	
NO.	NAME OF PART	NO. OF PART	QTY	MATERIAL	NOTES
DES.	ARKINE	DATE	2013/01/30	UNITS	mm
CHK.		DATE		SIZE	A4
APP.		DATE		SCALE	1:1
				DWG NO.	SP-2-1045A01
				REF:	Y0
上海联捷电气有限公司 Shanghai Elinker Electric CO., LTD				TITLE	LC16MG-5.08-XXP-140-00A LC16MG-5.08-成品