

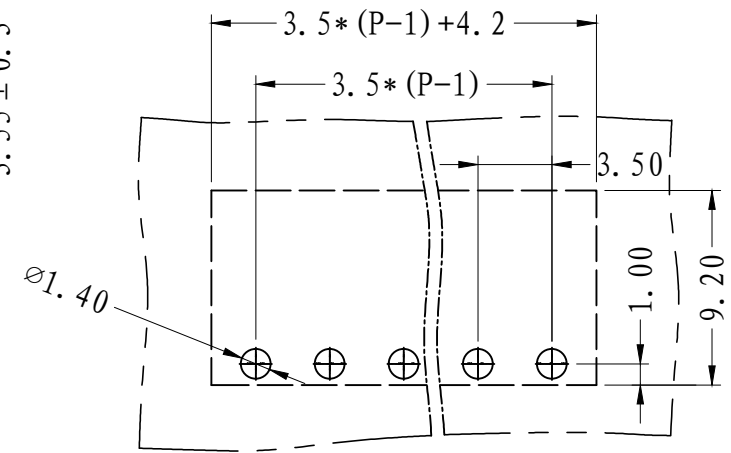

REVISION RECORD			
REV.	CONTENT	MOD.	DATE
△	初版发行		

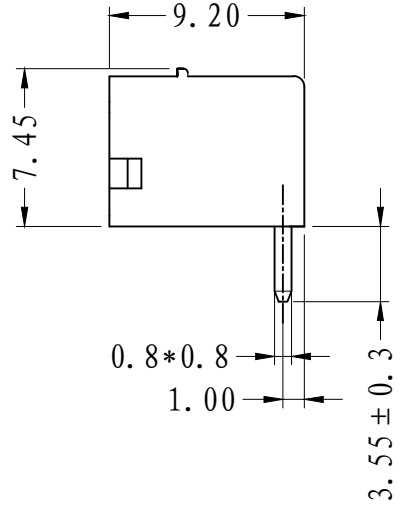
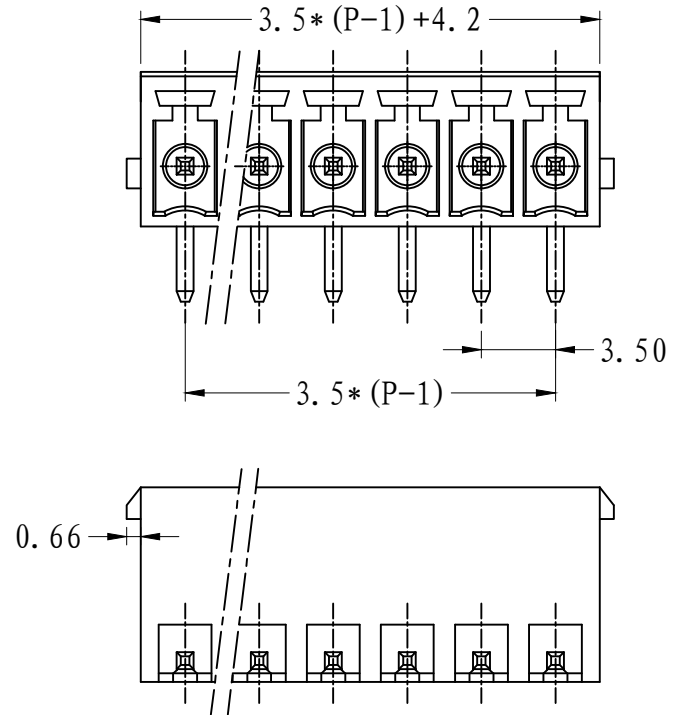

NOTES:
 Pitch : 3.5mm
 Rated Voltage : 300V
 Rated Current : 8 A
 Withstand Voltage :
 AC2500V for 1 minute
 Insulation Resistance :
 5MΩ / DC500V
 Using Temperature Range :
 -40℃ ~ +105℃

技术要求:
 间距: 3.5mm
 额定电压: 300V
 额定电流: 8A
 耐电压值: AC2500V/min
 绝缘阻抗: 5MΩ/DC500V
 使用条件: -40℃ ~ +105℃

	pitch dimension			Nominal dimension					— □ ○
	over 0 to 6	over 6 to 10	over 10 to 24	over 0 to 30	over 30 to 60	over 60 to 100	over 100 to 150	over 150	
variable range									
Tolerance	±0.1	±0.15	±0.25	±0.2	±0.3	±0.5	±0.7	±1.0	0.05/10

2	LZ1-3.5-弯针	1025B0001AV	P	黄铜	镀锡
1	LZ1L-3.5-针套	1260A0YXXAV	1	PA66	
NO.	NAME OF PART	NO. OF PART	Q'TY	MATERIAL	NOTES
DES.	吴央阳	DATE	24/03/01	UNITS	MM
CHK.	张华丰	DATE	24/03/01	SIZE	A4
APP.		DATE		SCALE	1:1
				DWG NO.	SP-2-1025001
				REV:	V0
 上海联捷电气有限公司 Shanghai Elinker Electric CO.,LTD				TITLE	LZ1RL-3.5-XP-1Y-00A
					LZ1RL-3.5-成品

REVISION		RECORD	
REV.	CONTENT	MOD.	DATE
△	初版发行		

NOTES:

Pitch : 3.81mm
 Rated Voltage : 300V
 Rated Current : 8 A
 Withstand Voltage :
 AC2500V for 1 minute
 Insulation Resistance :
 5MΩ / DC500V
 Using Temperature Range :
 -40℃ ~ +105℃

技术要求:
 间距: 3.81mm
 额定电压: 300V
 额定电流: 8A
 耐压值: AC2500V/min
 绝缘阻抗: 5MΩ/DC500V
 使用条件: -40℃~+105℃

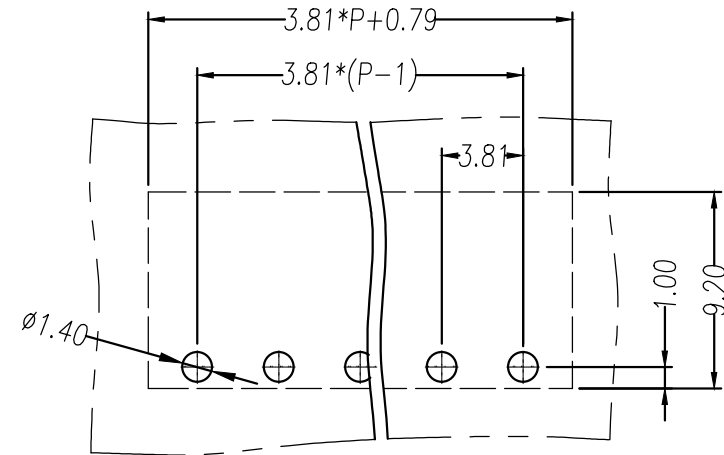
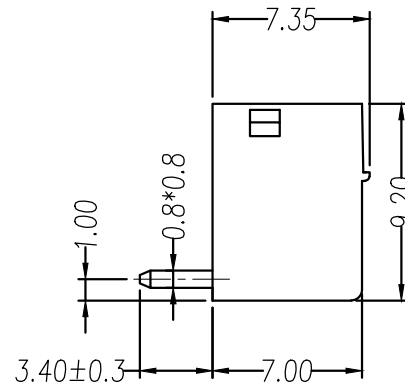
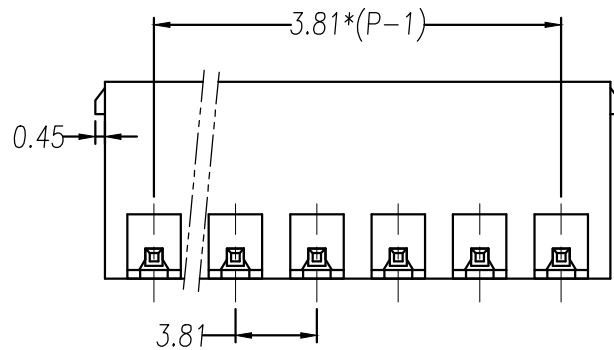
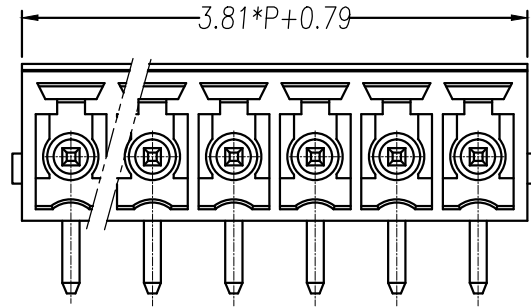

	pitch dimension			Nominal dimension					— ▱ ⌒
	over 0	over 6	over 10	over 0	over 30	over 60	over 100	over 150	
variable range	to 6	to 10	to 24	to 30	to 60	to 100	to 150		
Tolerance	±0.1	±0.15	±0.25	±0.2	±0.3	±0.5	±0.7	±1.0	0.05/10

2	LZ1-3.81-弯针	1003B0002AV	P	黄铜	镀锡
1	LZ1L-3.81-本体	1262A0YXXAV	1	PA66	
NO.	NAME OF PART	NO. OF PART	Q'TY	MATERIAL	NOTES
DES.	吴央阳	DATE 24/03/01	UNITS MM	THIRD ANGLE PROJECTION	SHEET
CHK.	张华丰	DATE 24/03/01	SIZE A4		1 of 1
APP.		DATE	SCALE 1:1	DWG NO. SP-2-1003004	REV: T0
上海联捷电气有限公司 Shanghai Elinker Electric CO.,LTD				TITLE	LZ1RL-3.81-XXP-1Y-00A LZ1RL-3.81-成品