

REVISION RECORD			
REV.	CONTENT	MOD.	DATE
△	初版发行		

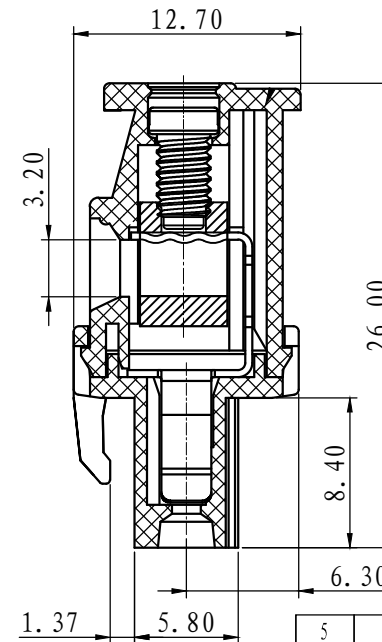
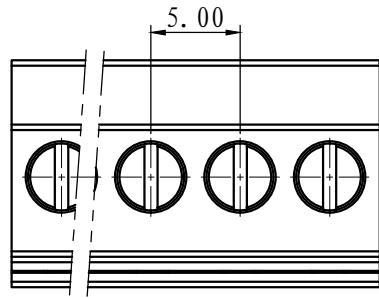

NOTES:

1. Voltage Rating: 300V, Current Rating: 15A
2. PITCH: 5.0mm
3. Insulation Withstands Voltage: AC2500V/min
4. Insulation Resistance: 500MΩ or more at DC500V
5. Using Temperature Range: -40° C - +105° C
6. Suitable Electric Wire: 30-12AWG
7. Screw Torque Value: 0.5 N.m以上

技术要求:

1. 额定电压: 300V, 额定电流: 15A
2. 间距: 5.0mm
3. 耐电压值: AC 2500V/min
4. 绝缘阻抗: 500兆欧
5. 使用条件: -40° - +105°
6. 适用线规: 30-12AWG
7. 螺丝扭力: 0.5 N.m

	pitch dimension			Nominal dimension					— /
	over 0 to 6	over 6 to 10	over 10 to 24	over 0 to 30	over 30 to 60	over 60 to 100	over 100 to 150	over 150	
variable range									□ ○
Tolerance	±0.1	±0.15	±0.25	±0.2	±0.3	±0.5	±0.7	±1.0	0.05/10

5	LC1-5.08-螺丝	SP0YB305503V	P	碳钢	三价铬钝化彩锌
4	LC1-5.08-铜方块	F1A0BLC5083V	P	黄铜	镀镍
3	LC2-5.08-夹子	1006B0001AV	P	磷青铜	镀镍
2	LC2-5.0-盖子	1124C0YXXAV	1	PA66-V0	
1	LC2-5.0-本体	1124A0YXXAV	1	PA66-V0	
NO.	NAME OF PART	NO. OF PART	Q' TY	MATERIAL	NOTES
DES.	LDD	DATE	2014/07/10	UNITS	MM
CHK.		DATE		SIZE	A4
APP.		DATE		SCALE	1:1
				DWG NO.	SP-1-1124A004
				REV:	V0
				TITLE	LC2A-5.0-XXP-1Y-00A
					LC2A-5.0-成品

REVISION RECORD			
REV.	CONTENT	MOD.	DATE
△	初版发行		

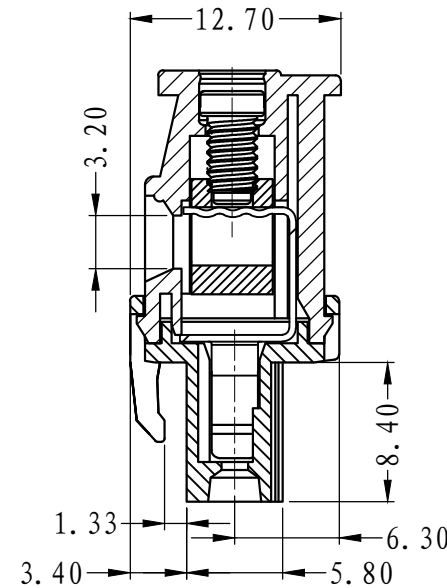
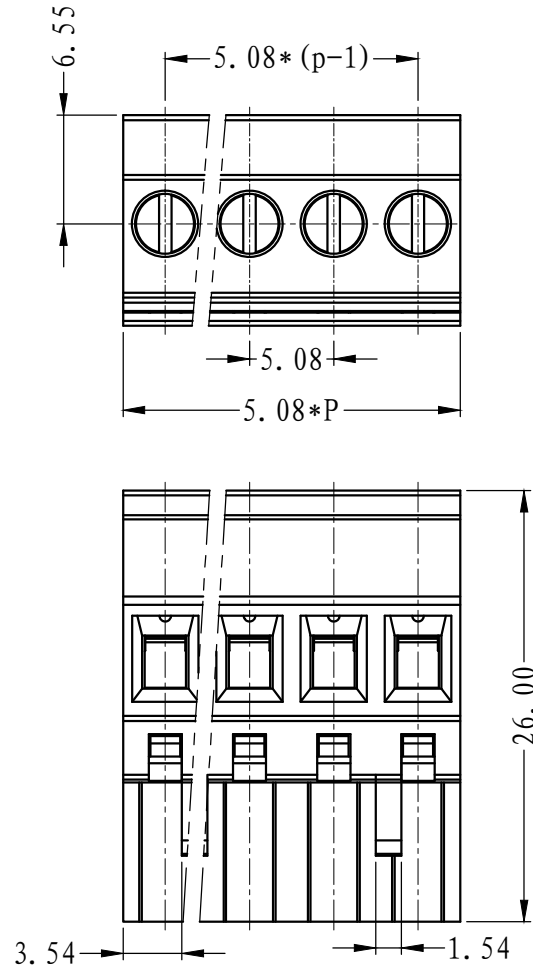

NOTES:

1. Voltage Rating: 300V, Current Rating: 15A
2. PITCH: 5.08mm
3. Insulation Withstands Voltage: AC2500V/min
4. Insulation Resistance: 500MΩ or more at DC1000V
5. Using Temperature Range: -40° C - +105° C
6. Suitable Electric Wire: 30-12AWG
7. Screw Torque Value: 0.5N.m以上

技术要求:

1. 额定电压: 300V, 额定电流: 15A
2. 间距: 5.08mm
3. 耐电压值: AC 2500V/min
4. 绝缘阻抗: 500兆欧
5. 使用条件: -40° - +105°
6. 适用线规: 30-12AWG
7. 螺丝扭力: 0.5N.m

	pitch dimension			Nominal dimension					— /
	over 0 to 6	over 6 to 10	over 10 to 24	over 0 to 30	over 30 to 60	over 60 to 100	over 100 to 150	— /	
variable range	0 to 6	6 to 10	10 to 24	0 to 30	30 to 60	60 to 100	100 to 150	— /	
Tolerance	±0.1	±0.15	±0.25	±0.2	±0.3	±0.5	±0.7	±1.0	0.05/10

5	LC1-5.08-铜方块	F1A0BLC5083V	P	黄铜	镀锌
4	LC1-5.08-螺丝	SPOYB305503V	P	碳钢	三价铬钝化彩锌
3	LC2-5.08-夹子	1006B0001AV	P	磷青铜	镀锌
2	LC2-5.08-主体	1006A0YXXAV	1	PA66-V0	
1	LC2-5.08-盖子	1006C0YXXAV	1	PA66-V0	
NO.	NAME OF PART	NO. OF PART	Q' TY	MATERIAL	NOTES
DES.	ARKINE	DATE	2011/02/28	UNITS	MM
CHK.		DATE		SIZE	A4
APP.		DATE		SCALE	1: 1
				DWG NO.	SP-2-1006001
				REV:	V0
				TITLE	LC2A-5.08-XXP-1Y-00A LC2A-5.08-成品