

REVISION RECORD			
REV.	CONTENT	MOD.	DATE
△	初版发行		

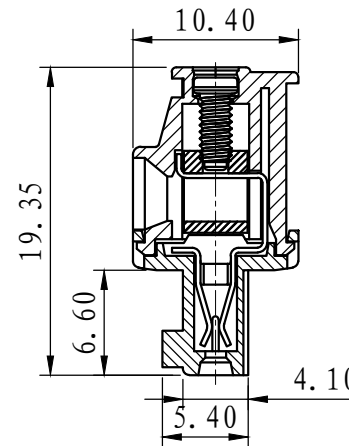
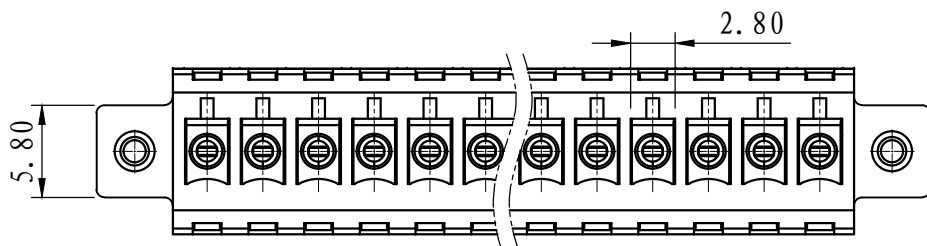
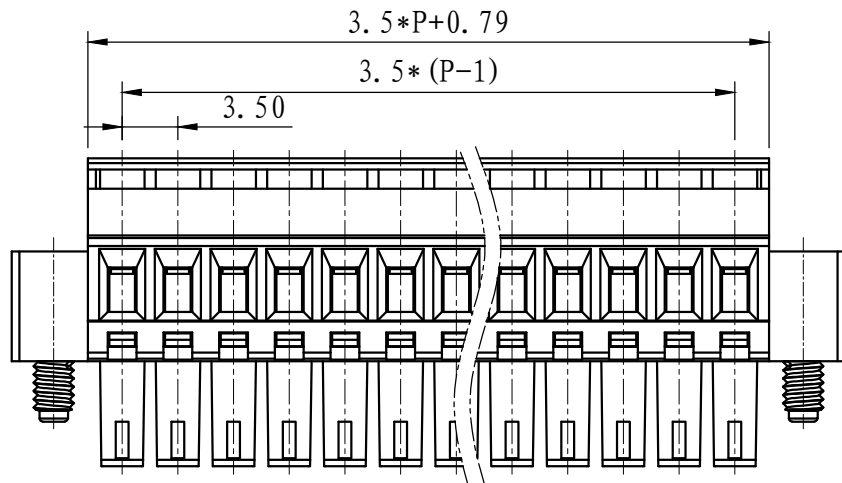
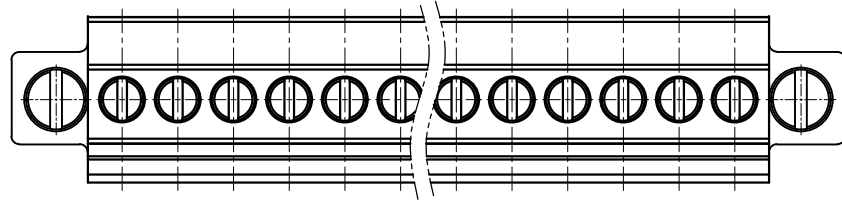

NOTES:

1. Voltage Rating: 300V, Current Rating: 8A
2. PITCH: 3.5mm
3. Insulation Withstands Voltage: AC2500V/min
4. Insulation Resistance: 500MΩ or more at DC500V
5. Using Temperature Range: -40° C - +105° C
6. Suitable Electric Wire: 30-14AWG
7. Screw Torque Value: 0.2N.m

技术要求:

1. 额定电压: 300V, 额定电流: 8A
2. 间距: 3.5mm
3. 耐电压值: AC 2500V/min
4. 绝缘阻抗500兆欧
5. 使用条件: -40° - +105°
6. 适用线规: AWG 30-14
7. 螺丝扭力: 0.2 N.m

	pitch dimension			Nominal dimension					—
	over 0 to 6	over 6 to 10	over 10 to 24	over 0 to 30	over 30 to 60	over 60 to 100	over 100 to 150	over 150	
variable range	0 to 6	6 to 10	10 to 24	0 to 30	30 to 60	60 to 100	100 to 150	150	□
Tolerance	±0.1	±0.15	±0.25	±0.2	±0.3	±0.5	±0.7	±1.0	○

5	LC1-3.81-螺丝	SPOYA204802V	P	碳钢	三价铬钝化彩锌
4	LC1-3.81-铜方块	F1A0BLC3813V	P	黄铜	镀镍
3	LC2-3.81-夹子	1022B0001AV	P	磷铜	镀镍
2	LC2-3.5-盖板	1128C40XXAV	1	PA66-V0	
1	LC2M-3.5-主体	1128M40XXAV	1	PA66-V0	
NO.	NAME OF PART	NO. OF PART	Q' TY	MATERIAL	NOTES
DES.	LDD	DATE	14-11-04	UNITS	MM
CHK.		DATE		SIZE	A4
APP.		DATE		SCALE	1:1
				DWG NO.	SP-1-1021001
				REV:	V0
				TITLE	LC2AM-3.5-XXP-1Y-00A
					LC2AM-3.5-成品

**上海联捷电气有限公司**  
 Shanghai Elinker Electric C.O., LTD

REVISION		RECORD	
REV.	CONTENT	MOD.	DATE
△	初版发行		

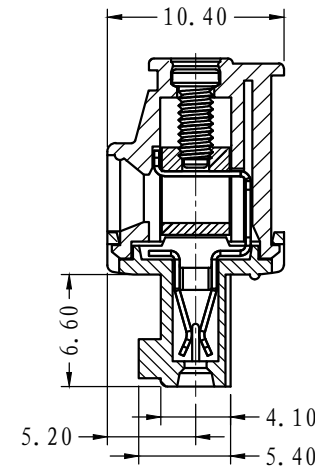
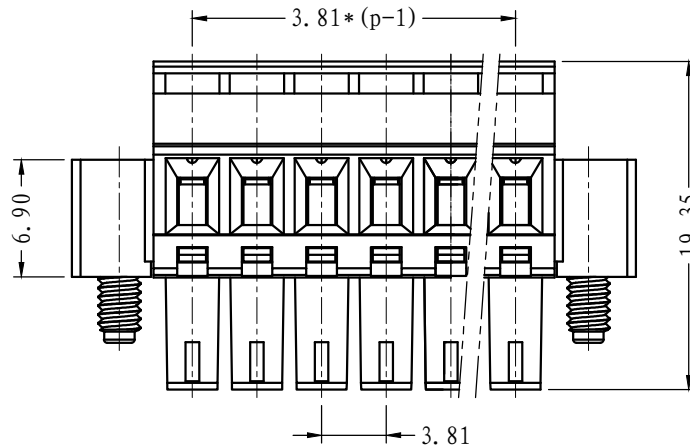
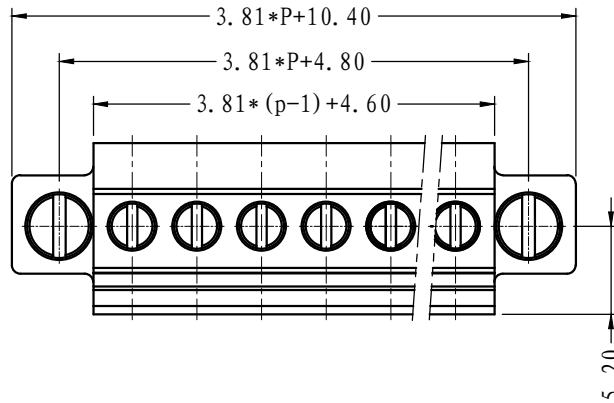

NOTES:

1. Voltage Rating: 300V, Current Rating: 8A
2. PITCH: 3.81mm
3. Insulation Withstands Voltage: AC2500V/min
4. Insulation Resistance: 500MΩ or more at DC500V
5. Using Temperature Range: -40° C - +105° C
6. Suitable Electric Wire: AWG 30-14
7. Screw Torque Value: 0.2N.m

技术要求:

1. 额定电压: 300V, 额定电流: 8A
2. 间距: 3.81mm
3. 耐电压值: AC 2500V/min
4. 绝缘阻抗: 500兆欧
5. 使用条件: -40° - +105°
6. 适用线规: AWG 30-14
7. 螺丝扭力: 0.2N.m

	pitch dimension			Nominal dimension					— ▱ ⌒
	over 0	over 6	over 10	over 0	over 30	over 60	over 100	over 150	
variable range	to 6	to 10	to 24	to 30	to 60	to 100	to 150		
Tolerance	±0.1	±0.15	±0.25	±0.2	±0.3	±0.5	±0.7	±1.0	0.05/10

6	LC1-系列-耳朵螺丝	SPOYA255301V	2	碳钢	三价铬钝化彩锌
5	LC1-3.81-螺丝	SPOYA204801V	P	碳钢	三价铬钝化彩锌
4	LC1-3.81-铜方块	F1A0BLC3813V	P	黄铜	镀镍
3	LC2-3.81-夹子	1022B0001AV	P	磷青铜	镀镍
2	LC2-3.81-盖板	1022C0YXXAV	1	PA66-V0	
1	LC2M-3.81-主体	1022M0YXXAV	1	PA66-V0	
NO.	NAME OF PART	NO. OF PART	Q' TY	MATERIAL	NOTES
DES.	ARKINE	DATE	11-05-20	UNITS	MM
CHK.		DATE		SIZE	A4
APP.		DATE		SCALE	1:1
				DWG NO.	SP-2-1022001
				REV:	V0
 <b>上海联捷电气有限公司</b> Shanghai Elinker Electric C.O.,LTD				TITLE	LC2AM-3.81-XXP-1Y-00A LC2AM-3.81-成品