

REVISION RECORD			
REV.	CONTENT	MOD.	DATE
△	初版发行		

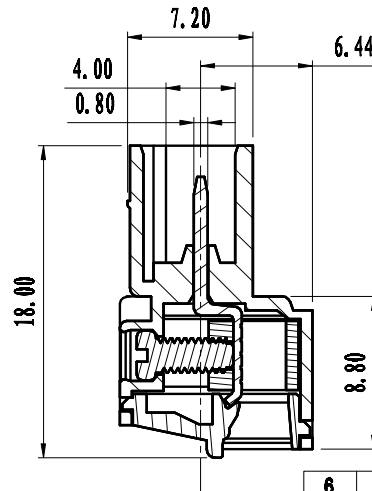
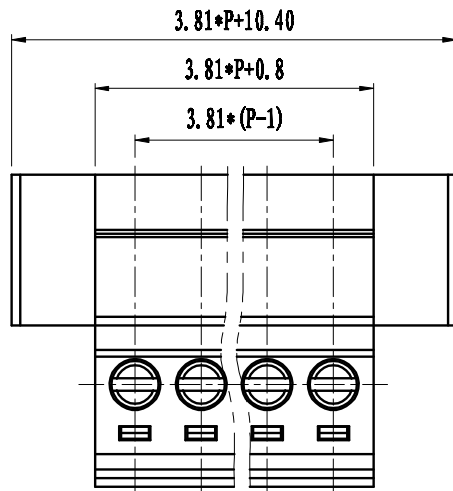
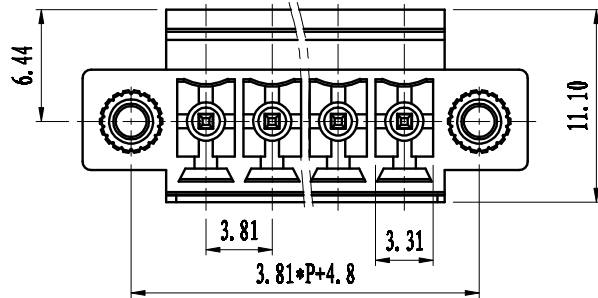

NOTES:

Pitch: 3.81mm Pole: 2-24P
 Rated Voltage: 300V
 Rated Current: 8A
 Withstand Voltage: AC2500V for 1 minute
 Insulation Resistance : 500MΩ/DC500V
 Using Temperature Range : -40° ^+150°
 Wire range : 30-16 AWG
 Screw Torque Value : 0.2N.m

技术要求:

间距: 3.81mm 极数: 2-24P
 额定电压: 300V
 额定电流: 8A
 耐电压值: AC 2500V/min
 绝缘阻抗: 500MΩ
 使用条件: -40℃ --+105℃
 适用线规: 30-16AWG
 螺丝扭矩: 0.2 N.m

6	LZ1-耳朵螺母	SNM0250010V	2	黄铜	
5	LC10-3.81方针	1054B0001AV	P	紫铜	镀雾锡
4	LC1-3.81-方块	F1A0BLC3813V	P	黄铜	镀锡
3	LC18-3.81-螺丝	SSM0200030V	P	碳钢	三价铬钝化彩锌
2	LC1-3.81盖板	1002C0YXXAV	1	PA66-V0	
1	LC10MG-3.81主体	1054M0YXXAV	1	PA66-V0	

NO.	NAME OF PART	NO. OF PART	QTY	MATERIAL	NOTES
DES.	LDD	DATE	2012/07/26	UNITS	mm
CHK.		DATE		SIZE	A4
APP.		DATE		SCALE	1:1

上海联捷电气有限公司 Shanghai Elinker Electric CO.,LTD				TITLE	LC10MG-3.81-XXP-1Y-00A LC10MG-3.81成品
---	--	--	--	-------	---

	pitch dimension			Nominal dimension					— /
	over 0	over 6	over 10	over 0	over 30	over 60	over 100	over 150	
variable range	0 to 6	6 to 10	10 to 24	0 to 30	30 to 60	60 to 100	100 to 150	150 to	▱ /
Tolerance	±0.1	±0.15	±0.25	±0.2	±0.3	±0.5	±0.7	±1.0	0.05/10