

REVISION RECORD			
REV.	CONTENT	MOD.	
△	初版发行		

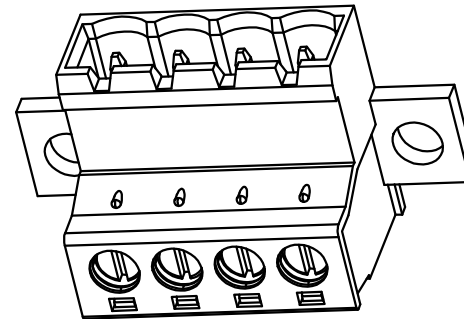

NOTES:

1. Voltage Rating: 300V, Current Rating: 15A
2. PITCH: 5.08mm
3. Insulation Withstands Voltage: AC2500V/min
4. Insulation Resistance: 500MΩ or more at DC500V
5. Using Temperature Range: -40° C - +105° C
6. Suitable Electric Wire: 24-12AWG
7. Screw Torque Value: 0.5Nm

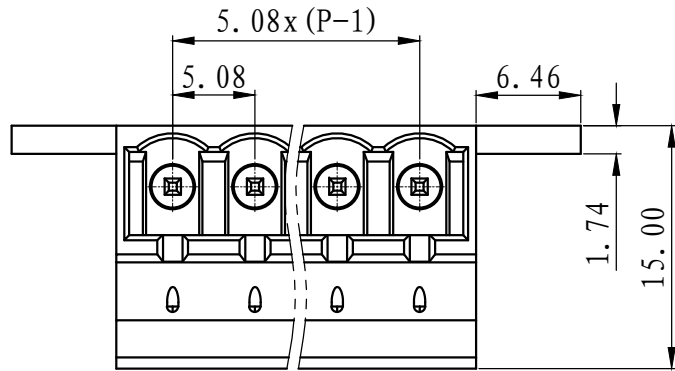
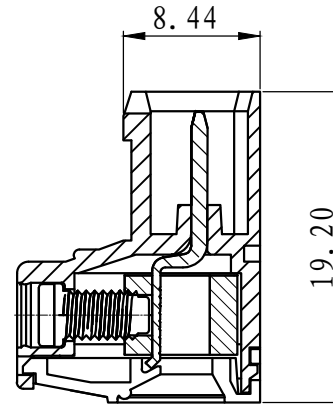
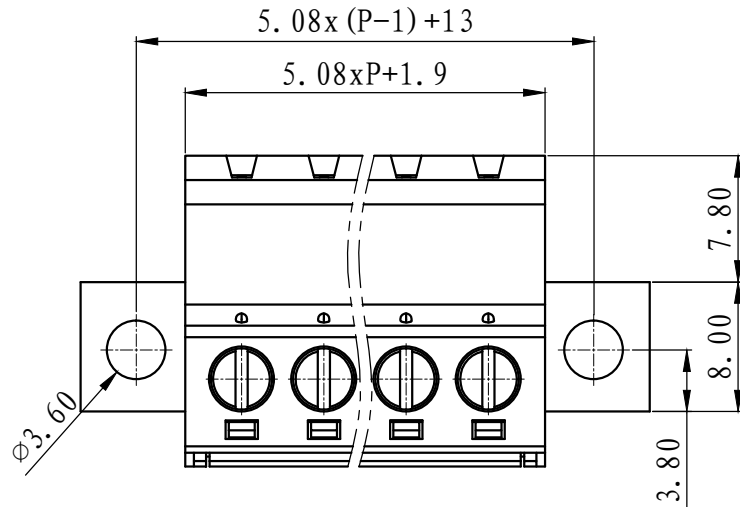

技术要求:

1. 额定电压: 300V, 额定电流: 15A
2. 间距: 5.08mm
3. 耐电压值: AC 2500V/min
4. 绝缘阻抗: 500兆欧
5. 使用条件: -40° - +105°
6. 适用线规: 24-12AWG
7. 螺丝扭力: 0.5N.m

	pitch dimension			Nominal dimension					— ◇ ○
	over 0	over 6	over 10	over 0	over 30	over 60	over 100	over 150	
variable range	to 6	to 10	to 24	to 30	to 60	to 100	to 150		
Tolerance	±0.1	±0.15	±0.25	±0.2	±0.3	±0.5	±0.7	±1.0	0.05/10

5	LC10-5.08-焊脚	1011B0001AV	P	紫铜	镀雾锡
4	LC1-5.08-螺丝	SPOYB305303V	P	碳钢	三价铬钝化彩锌
3	LC1-5.08-铜方块	F1A0BLC5083V	P	黄铜	镀镍
2	LC1-5.08-盖板	1001COYXXAV	1	PA66-V0	
1	LC10N-5.08-本体	1011TOYXXAV	1	PA66-V0	
NO.	NAME OF PART	NO. OF PART	Q' TY	MATERIAL	NOTES
DES.	ARKINE	DATE	2011/02/22	UNITS	MM
CHK.		DATE		SIZE	A4
APP.		DATE		SCALE	1:1
				DWG NO.	SP-2-1011T01
				REV:	V0
上海联捷电气有限公司 Shanghai Elinker Electric C.O.,LTD				TITLE	LC10N-5.08-XXP-1Y-00A LC10N-5.08-成品