

REVISION RECORD			
REV.	CONTENT	MOD.	DATE
△	初版发行		

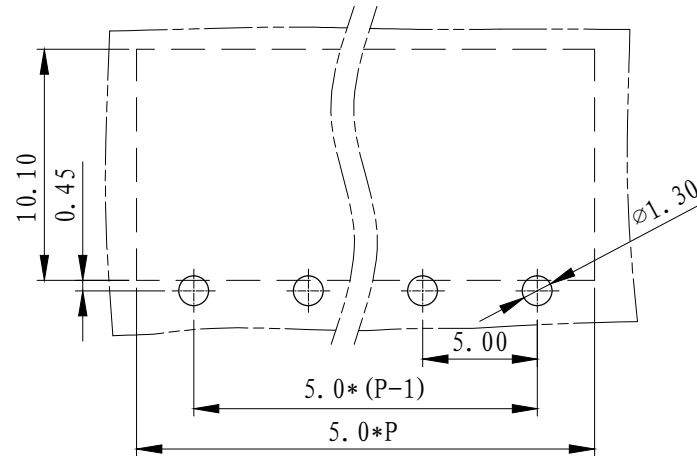

NOTES:

1. Voltage Rating: 300V, Current Rating: 8A
2. PITCH: 5.0mm
3. Insulation Withstands Voltage: AC2500V/min
4. Using Temperature Range: $-40^{\circ}\text{C} - +105^{\circ}\text{C}$
5. Suitable Electric Wire: 26-16AWG
6. Screw Torque Value: 0.5 N.m

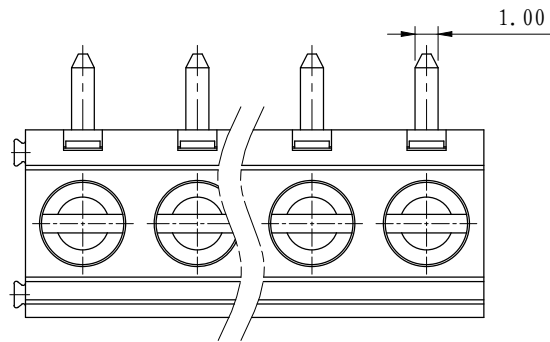
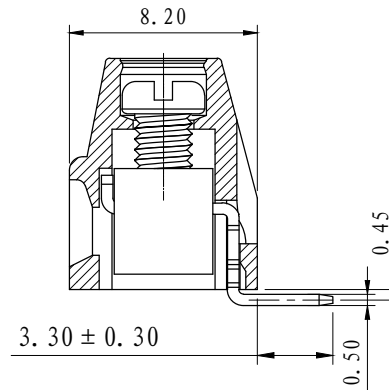
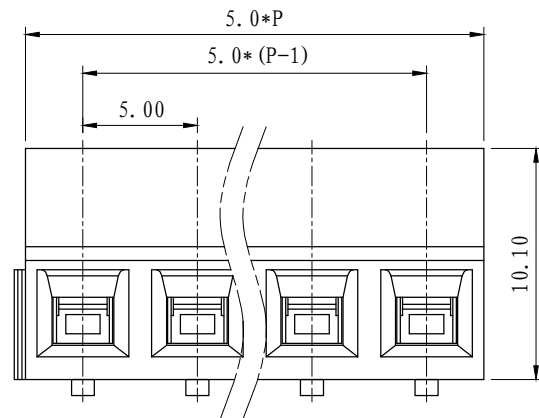

技术要求:

1. 额定电压: 300V, 额定电流: 8A
2. 间距: 5.0mm
3. 耐电压值: AC 2500V/min
4. 使用条件: $-40^{\circ} - +105^{\circ}$
5. 适用线规: 26-16AWG
6. 螺丝扭力: 0.5 N.m

	pitch dimension			Nominal dimension					— /
	over 0 to 6	over 6 to 10	over 10 to 24	over 0 to 30	over 30 to 60	over 60 to 100	over 100 to 150	over 150	
variable range									□ ○
Tolerance	±0.1	±0.15	±0.25	±0.2	±0.3	±0.5	±0.7	±1.0	0.05/10

4.	LG127R-短焊脚	2004B0002AV	P	黄铜	镀雾锡
3.	LG127-铜方块	F1A0BLG1273V	P	黄铜	镀镍
2.	LG127-螺丝 (M3*3.6)	SPOYA303601V	P	碳钢	三价铬钝化彩锌
1.	LG127-5.0-本体	2004A40XXAV-P	1	PA66-V0	
NO.	NAME OF PART	NO. OF PART	Q'TY	MATERIAL	NOTES
DES.	CMZ	DATE	2024/08/15	UNITS	MM
CHK.		DATE		SIZE	A4
APP.		DATE		SCALE	1:1
				DWG NO.	SP-2-2004001
				REV:	V0
上海联捷电气有限公司 Shanghai Elinker Electric C.O.,LTD				TITLE	LG127R-5.0-XXP-1Y-00A (M3孔)
					LG127R-5.0-成品

REVISION RECORD			
REV.	CONTENT	MOD.	DATE
△	初版发行		

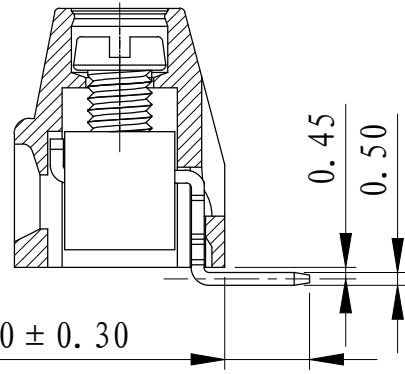
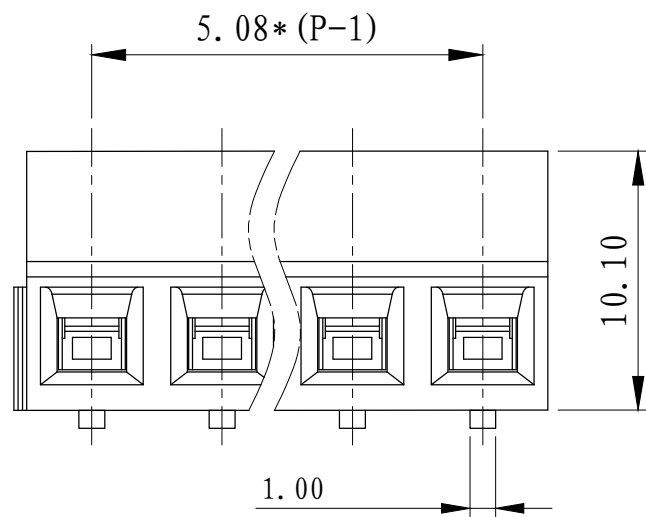
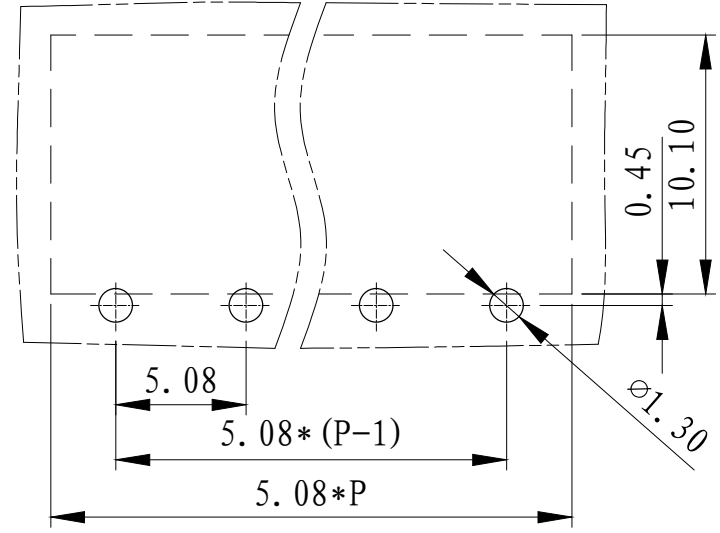
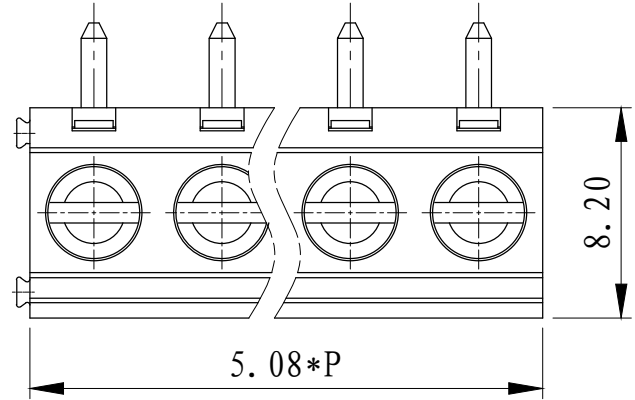

NOTES:

1. Voltage Rating: 300V, Current Rating: 8A
2. PITCH: 5.08mm
3. Insulation Withstands Voltage: AC2500V/min
4. Using Temperature Range: -40° C - +105° C
5. Suitable Electric Wire: 26-16AWG
6. Screw Torque Value: 0.5 N.m

技术要求:

1. 额定电压: 300V, 额定电流: 8A
2. 间距: 5.08mm
3. 耐电压值: AC 2500V/min
4. 使用条件: -40° - +105°
5. 适用线规: 26-16AWG
6. 螺丝扭力: 0.5 N.m

	pitch dimension			Nominal dimension					— /
	over 0 to 6	over 6 to 10	over 10 to 24	over 0 to 30	over 30 to 60	over 60 to 100	over 100 to 150	— /	
variable range	0 to 6	6 to 10	10 to 24	0 to 30	30 to 60	60 to 100	100 to 150	— /	
Tolerance	±0.1	±0.15	±0.25	±0.2	±0.3	±0.5	±0.7	±1.0	0.05/10

4.	LG127R-短焊脚	2004B00020V	P	黄铜	镀雾锡
3.	LG127-铜方块	F1A0BLG1273V	P	黄铜	镀镍
2.	LG127-螺丝 (M3*3.6)	SPOYA303601V	P	碳钢	三价铬钝化彩锌
1.	LG127-5.08-主体 (带拼接)	2023A4YXXAVP	1	PA66-V0	
NO.	NAME OF PART	NO. OF PART	Q'TY	MATERIAL	NOTES
DES.	CMZ	DATE 2024/08/16	UNITS	MM	THIRD ANGLE PROJECTION
CHK.		DATE	SIZE	A4	1 of 1
APP.		DATE	SCALE	1:1	DWG NO. SP-2-2004001 REV: V0
上海联捷电气有限公司 Shanghai Elinker Electric C.O.,LTD				TITLE	LG127R-5.08-XXP-1Y-00A (M3孔) LG127R-5.08-成品