

REVISION RECORD			
REV.	CONTENT	MOD.	DATE
▲	新发行		

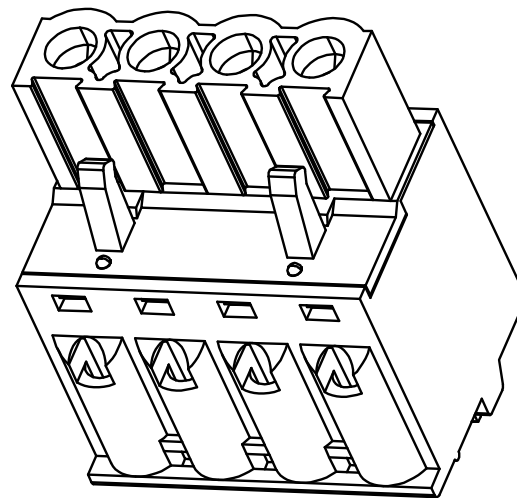

NOTES:
 Pitch : 5.0mm
 Rated Voltage : 300V
 Rated Current : 10A
 Withstand Voltage :
 AC2500V for 1 minute
 Insulation Resistance :
 500MΩ / DC500V
 Using Temperature Range :
 - 40℃ ~ + 105℃
 Wire range : 26~ 12AWG

技术要求:
 间距: 5.0mm
 额定电压: 300V
 额定电流: 10A
 耐电压值: AC2500V/min
 绝缘阻抗: 500MΩ/DC500V
 使用条件: -40℃~+105℃
 适用线规: 26~12AWG

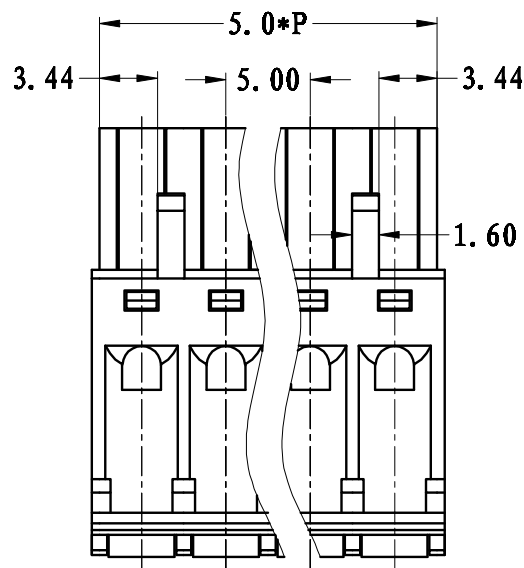
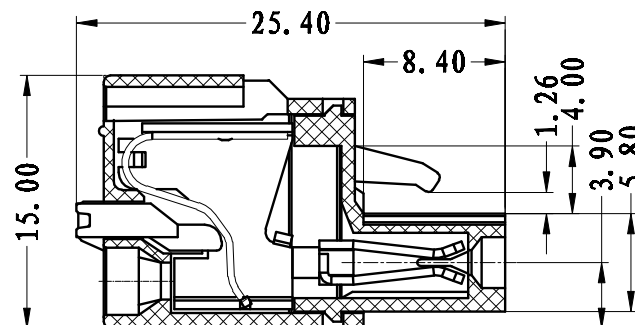
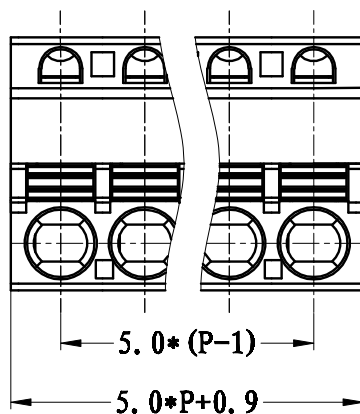

	pitch dimension			Nominal dimension					— /
	over 0	over 6	over 10	over 0	over 30	over 60	over 100	over 150	
variable range	to 6	to 10	to 24	to 30	to 60	to 100	to 150		□ ○
Tolerance	±0.1	±0.15	±0.25	±0.2	±0.3	±0.5	±0.7	±1.0	0.05/10

5	LC6-5.0-盖子	1152C4004AV	1	PA66-V0	
4	LC6-5.08-夹子	1020B0001AV	P	磷青铜	镀镍
3	LC6-5.08-弹片	F2A0DLC608BV	P	不锈钢	
2	LC6-5.08-按钮	1020D0YXXAV	P	PA66-V0	
1	LC6-5.0-主体	1152A4004AV	1	PA66-V0	
NO.	NAME OF PART	NO. OF PART	QTY	MATERIAL	NOTES
DES.	WL	DATE	2018/01/05	UNITS	MM
CHK.		DATE		SIZE	A4
APP.		DATE		SCALE	1:1
				DWG NO.	SP-1-1020002
				REV:	V0
上海联捷电气有限公司 Shanghai Blinker Electric C.O., LTD				TITLE	LC6-5.0-KXP-1Y-00A
					LC6-5.0-成品

REVISION RECORD			
REV.	CONTENT	MOD.	
△	新发行		

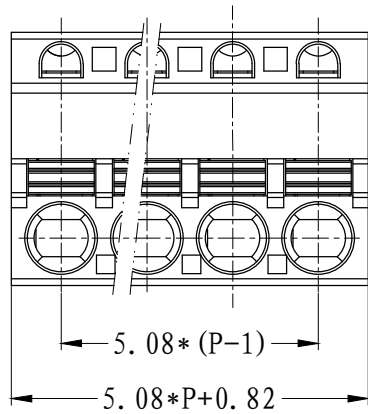
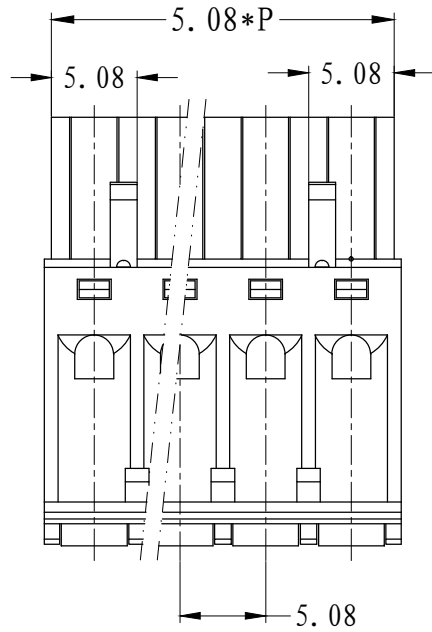

NOTES1:
UL Standard:
1.Voltage Rating: 300V, Current Rating: 10A

NOTES2:
1.Pitch : 5.08mm
2.Withstand Voltage : AC2500V for 1 minute
3.Using Temperature Range : - 40 ~ + 105
4.Suitable Electric Wire: 26-12AWG

技术要求1:
UL 标准:
1. 额定电压: 300V, 额定电流: 10A
技术要求2:
1. 间距: 5.08mm
2. 耐电压值: AC2500V/min
3. 使用条件: -40℃ ~ +105℃
4. 适用线规: 26-12AWG

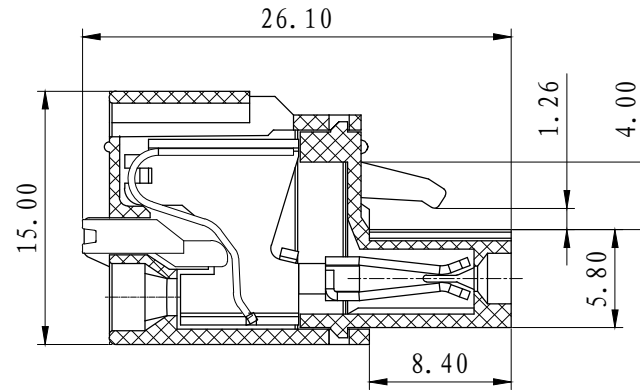

	pitch dimension			Nominal dimension					— ◇ ○
	over 0	over 6	over 10	over 0	over 30	over 60	over 100	over 150	
variable range	to 6	to 10	to 24	to 30	to 60	to 100	to 150		
Tolerance	±0.1	±0.15	±0.25	±0.2	±0.3	±0.5	±0.7	±1.0	0.05/10

5	LC6-5.08-盖子	1020C0YXXAV	1	PA66-V0	
4	LC6-5.08-夹子	1020B0001AV	P	磷青铜	镀镍
3	LC6-5.08-弹片	F2A0DLC608BV	P	不锈钢	
2	LC6-5.08-按钮	1020D0YXXAV	P	POM	
1	LC6-5.08-主体	1020M0YXXAV	1	PA66-V0	
NO.	NAME OF PART	NO. OF PART	Q' TY	MATERIAL	NOTES
DES.	CMZ	DATE 2025/03/25	UNITS	MM	THIRD ANGLE PROJECTION
CHK.		DATE	SIZE	A4	⊕
APP.		DATE	SCALE	1:1	DWG NO. SP-1-1020002 REV: V0
上海联捷电气有限公司 Shanghai Elinker Electric C.O,LTD				TITLE	LC6-5.08-XXP-1Y-00A LC6-5.08-成品