

REVISION RECORD

REV.	CONTENT	MOD.	DATE
△	新发行		

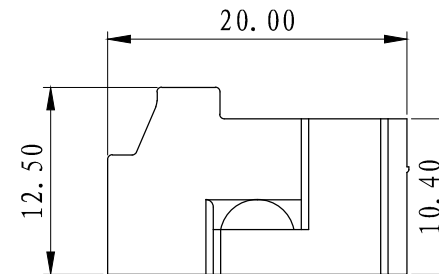
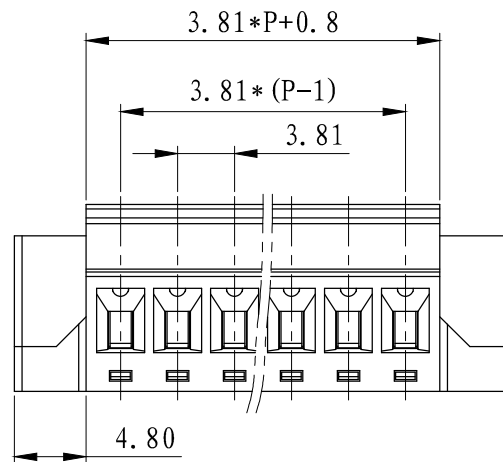
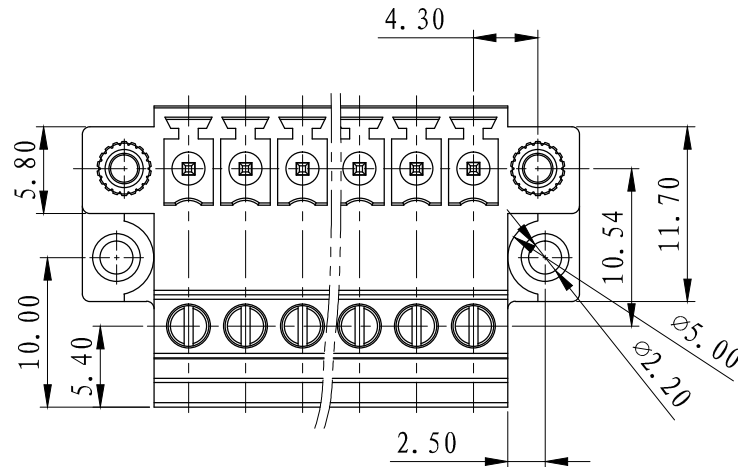

NOTES:

Pitch: 3.81mm Pole: 2-24P  
 Rated Voltage: 300V  
 Rated Current: 8A  
 Withstand Voltage:  
 AC2000V for 1 minute  
 Using Temperature Range :  
 -40° -+150°  
 Wire range : 28-16 AWG  
 Screw Torque Value : 0.2 N.m  
 Strip Length: 7mm

技术要求:

间距: 3.81mm 极数: 2-24P  
 额定电压: 300V  
 额定电流: 8A  
 耐电压值: AC 2000V/min  
 使用条件: -40℃ -+105℃  
 适用线规: 28-16AWG  
 螺丝扭矩: 0.2 N.m  
 剥线长度: 7mm

	pitch dimension			Nominal dimension					—
	over 0	over 6	over 10	over 0	over 30	over 60	over 100	over 150	
variable range	to 6	to 10	to 24	to 30	to 60	to 100	to 150		▱
Tolerance	±0.1	±0.15	±0.25	±0.2	±0.3	±0.5	±0.7	±1.0	○

6	LZ1-耳朵螺母	SNM0250010V	2	黄铜	
5	LC18-3.81方针	1051B0001AV	P	紫铜	镀雾锡
4	LC1-3.81-方块	F1A0BLC3813V	P	黄铜	镀镍
3	LC1-3.81-螺丝	SP0YA204801V	P	碳钢	三价铬钝化彩锌
2	LC18-3.81盖板	1052C40XXA0	1	PA66-V0	
1	LC18M-3.81主体	1052M40XXAV	1	PA66-V0	
NO.	NAME OF PART	NO. OF PART	Q'TY	MATERIAL	NOTES
DES.	CMZ	DATE 2025/09/25	UNITS	mm	THIRD ANGLE PROJECT
CHK.		DATE	SIZE	A4	1 of 1
APP.		DATE	SCALE	1:1	DWG NO. SP-1-1052M400 REV: V0
上海联捷电气有限公司 Shanghai Elinker Electric CO.,LTD				TITLE	LC18M-3.81-XXP-1Y-00A LC18M-3.81成品